

## Charge Pump Flash LED Driver with Safety Timer

### DESCRIPTION

The EUP3618 is a large-current charge pump designed specifically for white LEDs used in camera flash applications. Only one small bucket capacitor is required to develop the output drive, providing a low EMI solution compared with inductive boost regulator.

The EUP3618 has two operation modes: Flash mode and Movie mode. In Flash mode, the EUP3618 is capable of delivering up to 700mA. A safety timer is also included to ensure the LED can not be on indefinitely and overheat.

The EUP3618 is available in a 10-pin TDFN package.

### FEATURES

- Input Voltage Range — 2.7V to 5.5V
- Flash and Movie — Two Selectable Modes
- Up to 700mA Output Current — Flash Mode
- Flash Mode Safety Timer Shut-Off
- 1X and 2X Automatic Mode for High Efficiency
- External Flash Control Pin for Synchronization to a Camera Module or Graphics Controller
- Short-Circuit, Over-Voltage, Over-Current and Over-Temperature Protection
- Soft-Start Functionality
- 3mm×3mm TDFN-10 Package
- RoHS Compliant and 100% Lead (Pb)-Free Halogen-Free

### APPLICATIONS

- Mobile Camera Phones
- Digital Cameras
- PDAs with Built-In Cameras

### Typical Application Circuit

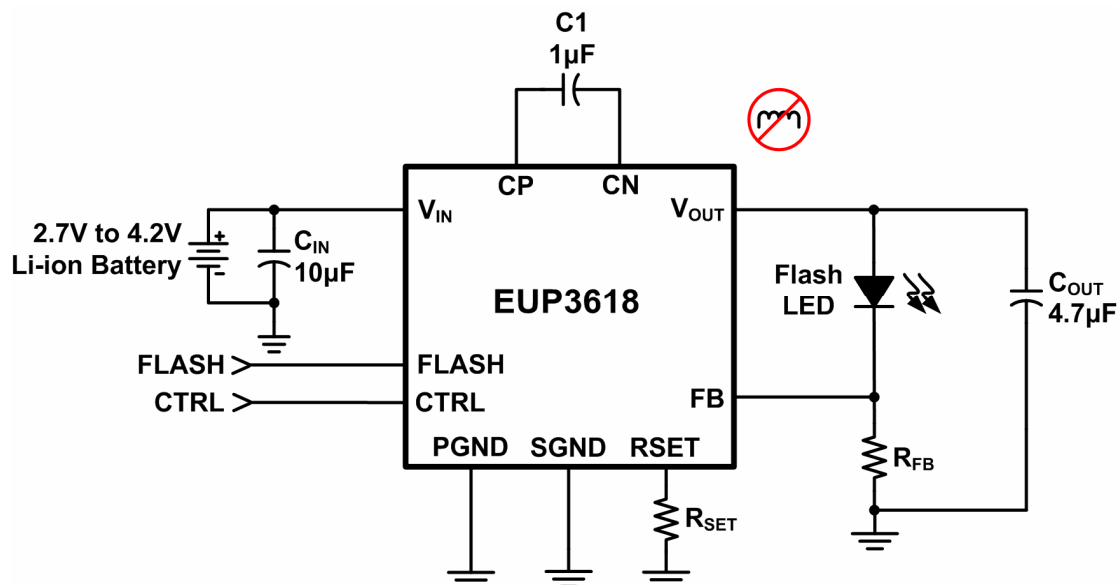

Figure 1.

## Pin Configurations

Package Type	Pin Configurations
TDFN-10	<p>(TOP VIEW)</p>

## Pin Description

PIN	TDFN-10	DESCRIPTION
1	$V_{IN}$	Input voltage.
2	CP	Positive terminal of fly capacitor.
3	CN	Negative terminal of fly capacitor.
4	FLASH	Flash mode enable pin. Puts the device in active Flash mode when high.
5	CTRL	Control input bit. Used to enable and set the output current in Movie mode.
6	RSET	Connect a resistor from this pin to ground. In Flash mode (FLASH=High) this resistor sets the current regulation point according to the following: $V_{FB}=(1.2V/R_{SET})*12.5K\Omega$
7	FB	Current-setting reference pin. Connect to the LED cathode and the current setting resistor.
8	SGND	Ground. Control circuitry returns current to this pin.
9	PGND	Power ground. Fly capacitor current returns through this pin.
10	$V_{OUT}$	Output pin. Connect to the LED anode.

## Ordering Information

Order Number	Package Type	Marking	Operating Temperature Range
EUP3618JIR1	TDFN-10	XXXXX P3618	-40 °C to 85°C

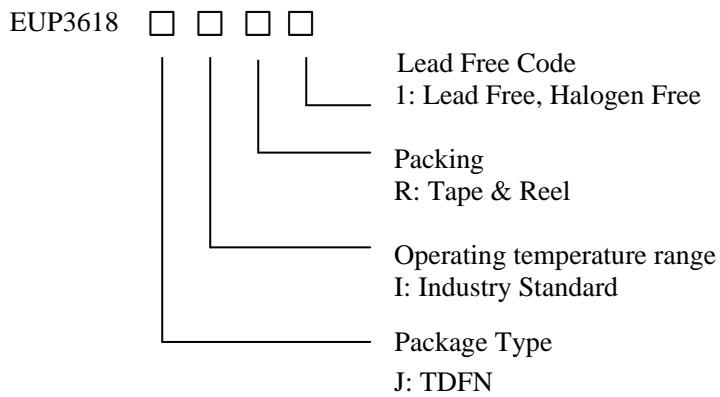

## Block Diagram

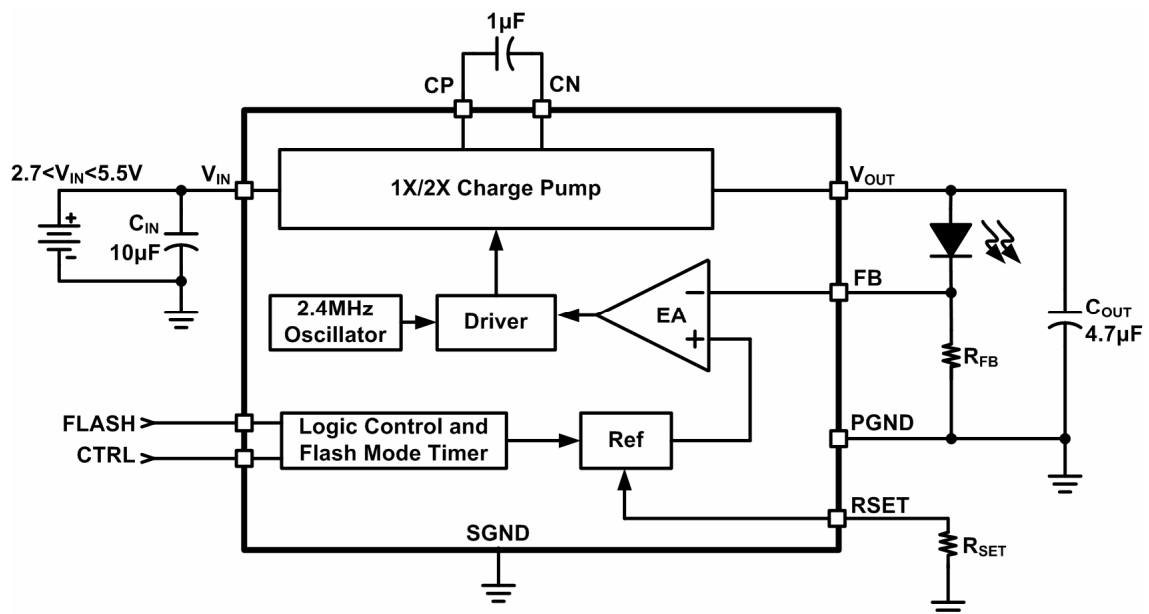

Figure 2.

**Absolute Maximum Ratings (1)**

- $V_{IN}(V), V_{OUT}(V)$  ----- -0.3V to 6.5V
- $CP, CN(V)$  ----- -0.3V to  $(V_{OUT}+0.3V)$
- Junction Temperature Range -----  $-40^{\circ}C$  to  $150^{\circ}C$
- Lead Temperature Range -----  $260^{\circ}C$
- Storage Temperature Range -----  $-60^{\circ}C$  to  $150^{\circ}C$

**Recommend Operating Conditions (2)**

- Operating Temperature Range -----  $-40^{\circ}C$  to  $85^{\circ}C$
- Thermal Resistance  $\theta_{JA}$  (TDFN-10) -----  $69^{\circ}C/W$

Note(1): Stress beyond those listed under “Absolute Maximum Ratings” may damage the device.

Note(2): The device is not guaranteed to function outside the recommended operating conditions.

**Electrical Characteristics**

Unless otherwise specified:  $T_A = 25^{\circ}C$  for TYP;  $C_1 = 1\mu F$ ,  $C_{OUT} = 4.7\mu F$  (ESR < 0.1 $\Omega$ );  $C_{IN} = 10\mu F$ ;  $V_{IN} = 3.6V$ .

Symbol	Parameter	Conditions	EUP3618			Units
			Min.	Typ.	Max.	
$V_{IN}$	Input Voltage		2.7		5.5	V
$I_Q$	Quiescent Current	Flash Low		0.5		mA
		Flash High, 2X mode		4		
$I_{SH}$	Shutdown Current	$V_{EN} = 0V$			1	$\mu A$
$V_{FB}$	FB Reference Voltage	Flash High, $R_{SET} = 100K\Omega$		150		mV
		Flash Low		50		
$R_{OUT}$	Output Resistance (open loop)	1X mode, $I_{OUT} = 200mA$		0.7		$\Omega$
		2X mode, $I_{OUT} = 200mA$		6		
$t_{FLASH}$	Flash Mode Pulse Duration	$3.3V < V_{IN} < 4.2V$ , $V_{OUT} > 3.3V$ , $I_{OUT} = 500mA$			500	ms
$t_{START}$	Flash Mode Start-Up time				1	ms
$t_{SAFE}$	Flash Mode Safety Timer		0.8	1	1.2	s
$F_{OSC}$	Charge Pump Frequency	Device Enabled		2.4		MHz
$I_{SC}$	Output Short Circuit Current Limit	$V_{OUT} < 0.5V$		180		mA
$V_{HI}$	Logic High Level	Flash, CTRL	1.4			V
$V_{LO}$	Logic Low Level	Flash, CTRL			0.4	
$I_{IH}$	Input Leakage	Flash, CTRL	-1		1	$\mu A$
$I_{IL}$	Input Leakage	Flash, CTRL	-1		1	
$t_{LO}$	Low Logic Hold Time		2		75	$\mu s$
$t_{HI}$	High Logic Hold Time		2		75	$\mu s$
$t_{OFF}$	Turn Off Time for CTRL Signal			500		$\mu s$
$t_{LAT}$	Latch Time for CTRL Signal			500		$\mu s$
$T_{SD}$	Thermal Shutdown			145		$^{\circ}C$
$T_{HYS}$	Thermal Hysteresis			25		$^{\circ}C$

Typical Operating Characteristics ( $C_{IN}=10\mu F$ ,  $C_{OUT}=4.7\mu F$ ,  $C1=1\mu F$ , unless otherwise noted.)

### Ripple 1X Movie 150mA

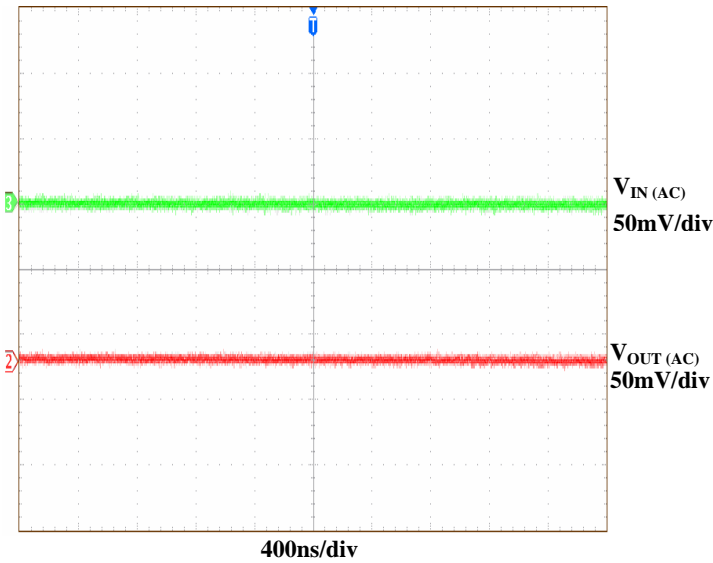

### Ripple 1X Flash 500mA

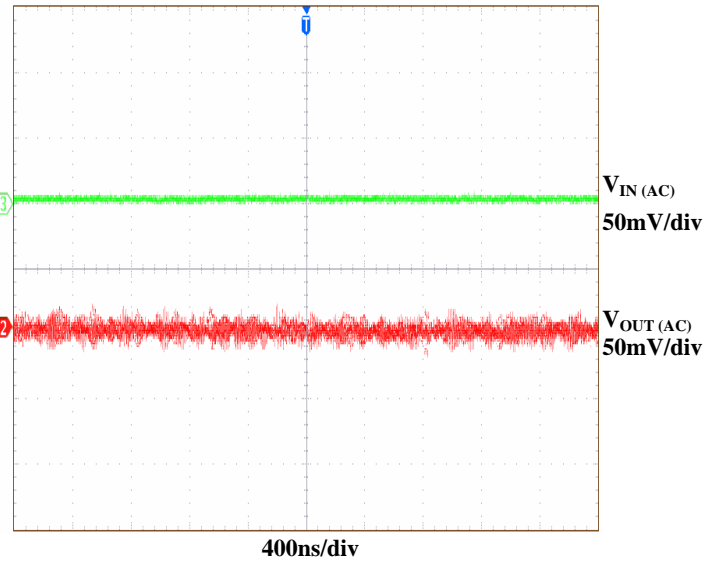

### Ripple 2X Movie 150mA

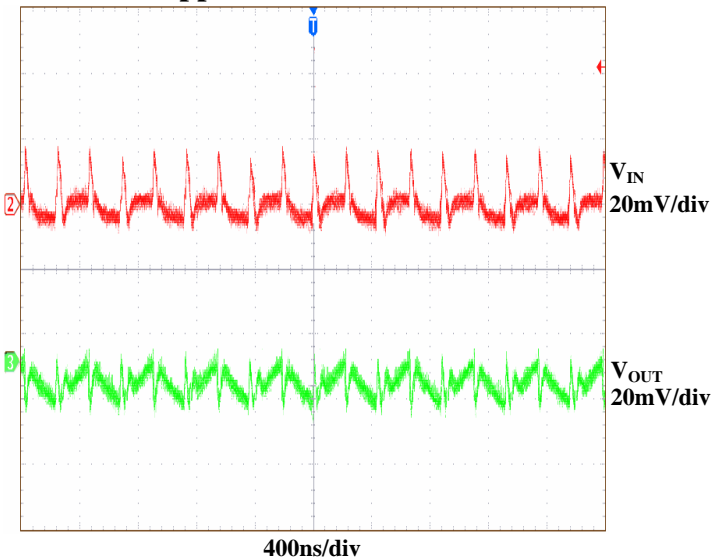

### Ripple 2X Flash 500mA

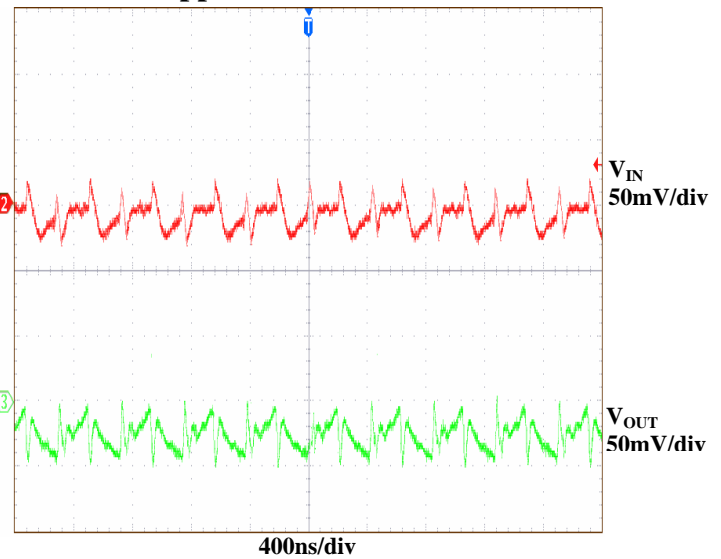

### Startup 150mA Movie Mode

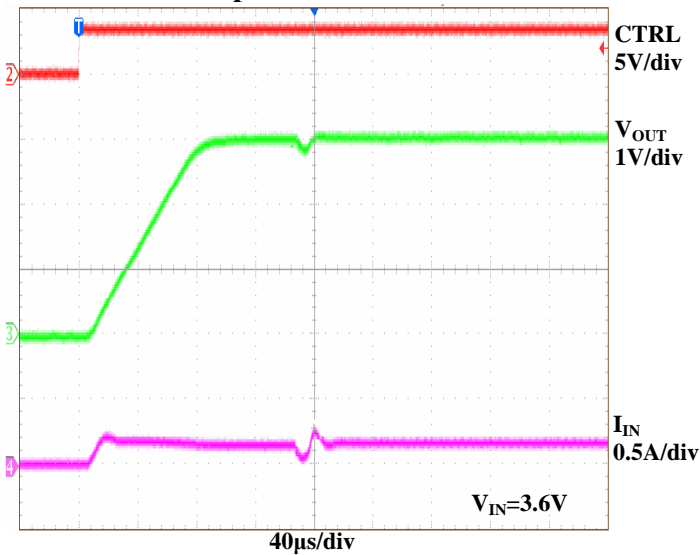

### Startup 500mA Flash in 1X Mode

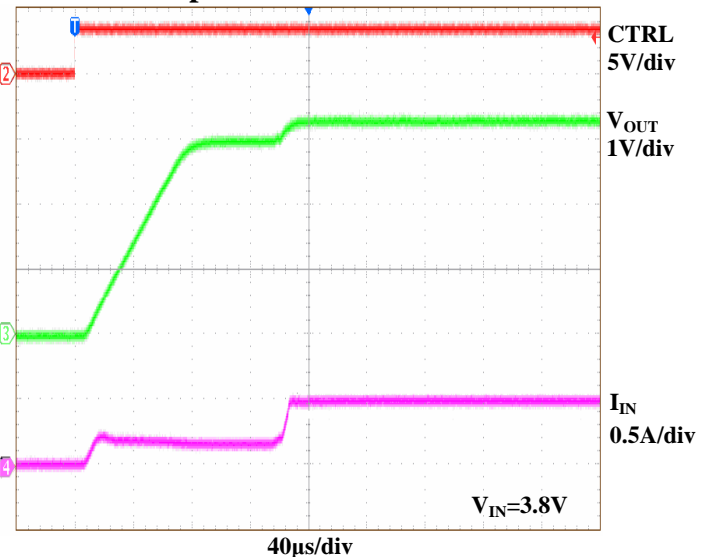

## Typical Operating Characteristics (continued)

### Startup 500mA Flash Mode 1X to 2X

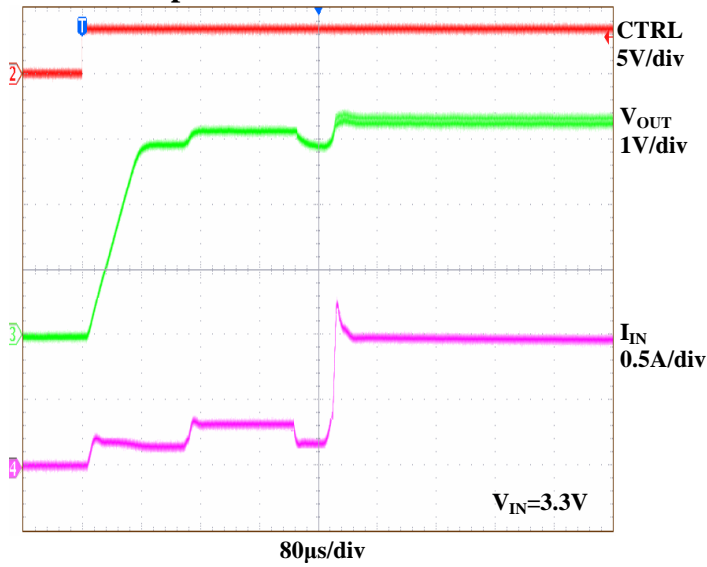

### Movie in 1X to Flash in 1X

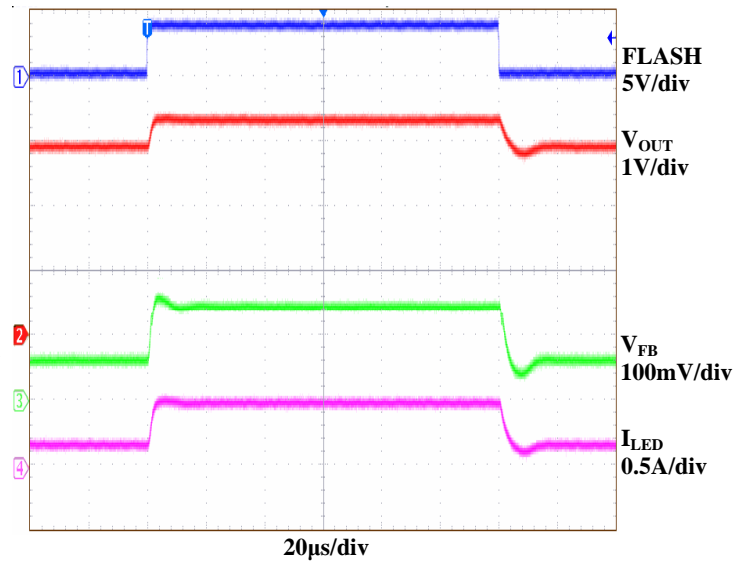

### Movie in 1X to Flash in 2X Mode

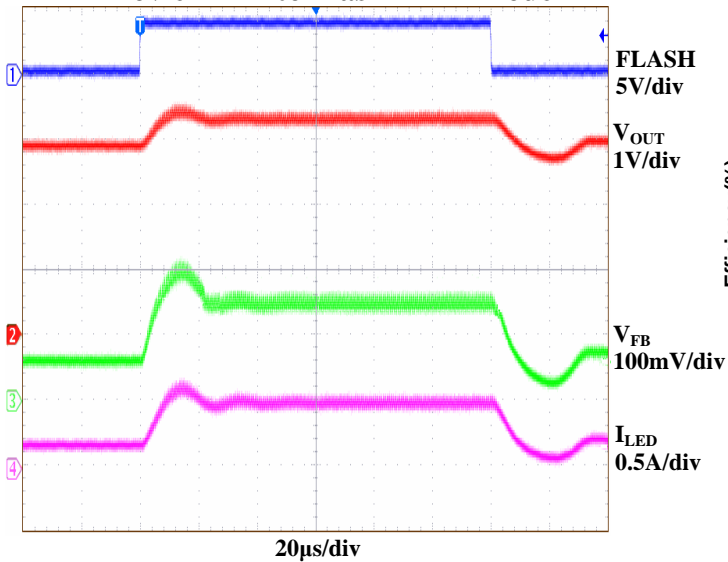

### Efficiency vs. Input Voltage

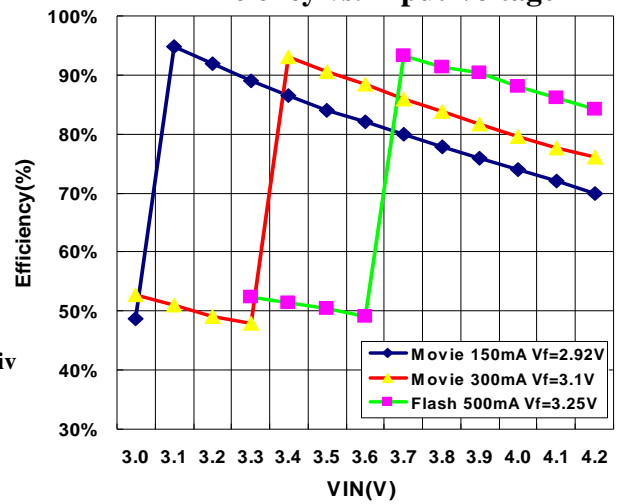

## Applications Information

### General Operation

The EUP3618 is a large-current charge pump designed specifically for white LEDs used in camera flash applications. 2.4MHz fixed-frequency switching allows for tiny external components and low output ripple. The EUP3618 has two operation modes which are pin selectable for either Flash or Movie mode. Operation begins after the enable pin CTRL receive a logic high, the device goes through a soft-start mode to reduce inrush current. The EUP3618 starts in the 1X mode, which acts like a linear regulator to control the output current by sensing the feedback pin FB. The load and supply conditions determine whether the charge pump operates in 1X or 2X mode.

### LED Current

The LED current is set by  $R_{FB}$  and  $V_{FB}$ ,

$$I_{LED} = V_{FB} / R_{FB} \quad (1)$$

The feedback voltage  $V_{FB}$  is difference between Flash and Movie mode. When in Flash mode (FLASH is high), the  $V_{FB}$  is set by the resistor  $R_{SET}$  connected between the RSET pin and SGND. The voltage of FB is

$$V_{FB} = (1.2 / R_{SET}) * 12.5K\Omega \quad (2)$$

Where 1.2V is the internal bandgap reference voltage and 12.5K $\Omega$  is an internal resistance used to scale the RSET current. Typical values of  $R_{SET}$  are 50K $\Omega$  to 200K $\Omega$  for a range of  $V_{FB}$ =300mV to 75mV in Flash mode.

In Movie mode (FLASH is low), the  $V_{FB}$  is programmed by the pulse number of the CTRL input.

Table 1. Voltage of FB ( $R_{FB} = 0.33\Omega$ )

Pulse	$V_{FB}$ (typ)	$I_{LED}$ (typ)
1	50mV	151mA
2	60mV	182mA
3	70mV	212mA
4	80mV	242mA
5	100mV	303mA
6	120mV	364mA
7	140mV	424mA
$\geq 8$	170mV	515mA

### Timing Control

The CTRL pin timing control required to meet as shown in Figure 3.  $t_{HI}$  and  $t_{LO}$  is the duration of high and low of input pulse signal.  $t_{LAT}$  is the data latch time, when CTRL has been held in the high state for time greater than  $t_{LAT}$ , the pulse signal is valid latched.  $t_{OFF}$  is the shutdown time, when CTRL has been held in the low state for time greater than  $t_{OFF}$ , the EUP3618 enters into shutdown mode.

When the time of the high held less than  $t_{HI}(\text{min.})$  or the low held less than  $t_{LO}(\text{min.})$ , this pulse is invalid.

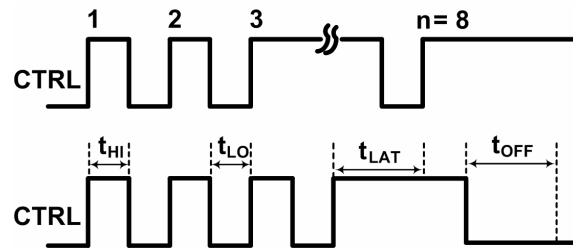

Figure 3.

### Over-Temperature Protection

The OTP circuit prevents the device from overheating and experiencing a catastrophic failure. When the junction temperature exceeds 150°C the device is disable. It remains disabled until the junction temperature drops below this threshold. Hysteresis is included to prevent toggling between modes.

### Over-Voltage Protection

Output OVP prevents the EUP3618 from generating an output voltage that could damage other devices connected to it such as load LEDs and bypass capacitors. When the output voltage exceeds 5.8V, the OVP circuit disables the charge pump until the voltage decreases to a level within the acceptable range. This circuit allows the device to drive LEDs with high forward voltage at a reduced level without exceeding the output voltage limits specified for the device.

### Over-Current Protection

When the EUP3618 is in 2X mode, the input current will be approximately double the required output. When the steady-state load requires the maximum current available in 2X mode, The OCP circuit prevents the device from overheating from excessive power dissipation. This feature protects the device when in 1X mode.

### Capacitor Selection

The EUP3618 charge pump circuit requires 3 capacitors: input, output and fly capacitors. A 1 $\mu$ F capacitor is typically recommended. For the input capacitor, a larger value of 2.2 $\mu$ F or 4.7 $\mu$ F will help reduce input voltage ripple. All the capacitors should be ceramic to obtain low ESR for high performance. The input and output capacitors should be located as close as possible to the  $V_{IN}$  and  $V_{OUT}$  pins to obtain best bypassing, and the returns should be connected directly to the PGND pin. And the fly capacitor will be close to CP and CN pin.

### TDFN-10

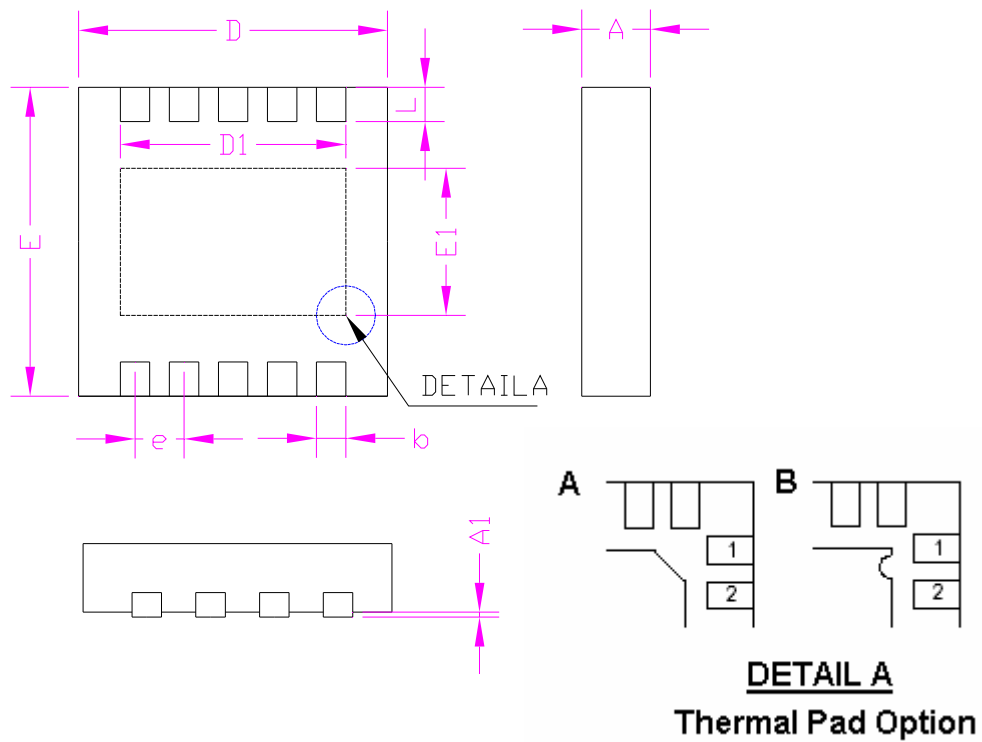

Note: Exposed pad outline drawing is for reference only.

SYMBOLS	MILLIMETERS			INCHES		
	MIN.	Normal	MAX.	MIN.	Normal	MAX.
A	0.70	0.75	0.80	0.028	0.030	0.031
A1	0.00	-	0.05	0.000	-	0.002
D	2.90	3.00	3.10	0.114	0.118	0.122
D1	2.30	2.60	2.65	0.091	0.102	0.104
E	2.90	3.00	3.10	0.114	0.118	0.122
E1	1.50	1.65	1.75	0.059	0.065	0.069
L	0.30	0.40	0.50	0.012	0.016	0.020
b	0.18	-	0.30	0.007	-	0.012
e	0.50 REF			0.020 REF		